

DSP5053 DSP5153 DSP5253

30W 5.25" Two Way Commercial Pendant Speaker



Description

This series offers multi-functional loudspeakers available in wall-mount, pendant, and floor-standing configurations. These speakers deliver high-quality voice and music reproduction along with a relatively long sound transmission distance. They are well suited for conference rooms, shopping malls, exhibition halls, and other indoor and outdoor venues.

Features

- Applications: Suitable for public address and background music playback.
- Sound quality: Delivers clear, bright audio for an exceptional listening experience.
- Driver materials: Features high-quality PP material for the woofer cone, rubber edge moisture-proof treatment, and a silk dome tweeter for excellent tone and sound performance.
- Design: Simple, elegant appearance with a fine round-hole diffusion pattern on the grille — beautiful, durable, and blends seamlessly into any environment.
- Enclosure: Made of high-strength ABS material for rugged durability.
- Installation: Includes a mounting bracket for easy setup.

Specifications

Model		DSP5053	DSP5153	DSP5253
Speaker Unit		5.25"×1+1"×1		
Rated Power (RMS)		30W		
Power Adjustment	70V	1.25W-2.5W-4W-8W-15W		
	100V	2.5W-5W-8W-15W-30W		
	8Ω	30W		
Sensitivity (1m, 1W)		86dB±2dB		
MAX. SPL. (1m)		101dB±2dB		
Frequency Response		110Hz~20kHz		
Dimensions (H×W×D)		ø185×255mm		

Product Information

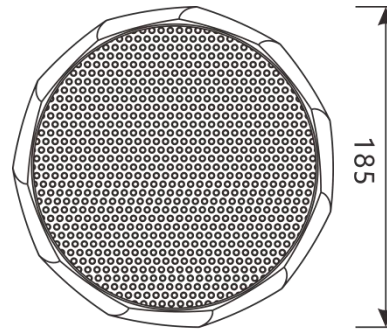
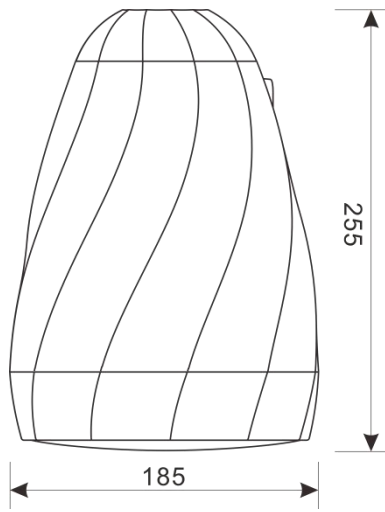

Unit: mm

Frequency Response

(dB SPL, 1W, 1m)

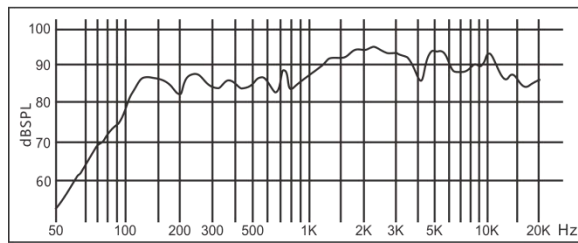

Distortion

(THD < 5% 1W, 1m, 100Hz-10kHz)

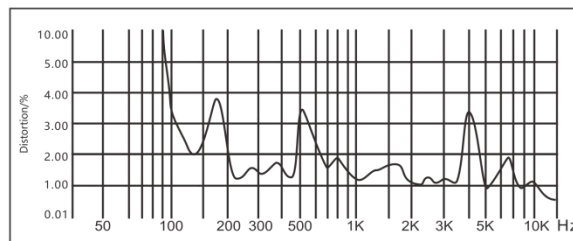

Directivity

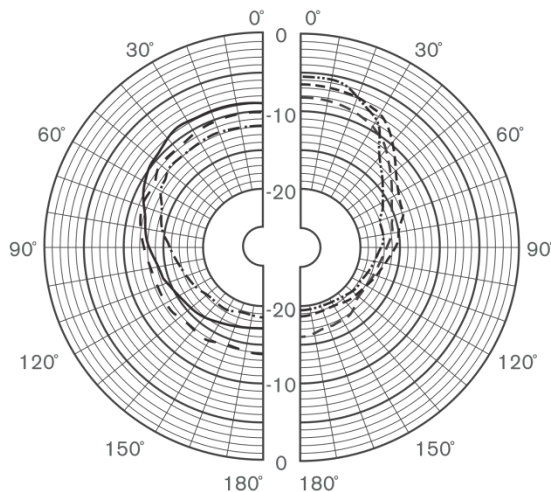

- 250 Hz
- 500 Hz
- 1000 Hz
- 2000 Hz
- 4000 Hz
- 8000 Hz